

TECHNICAL SPECIFICATION

FOR

G83-6000

Revision: 01

Page 1 of 32

LAB
TBE
QS-T
VKT

MODIFICATIONS

Rev.	Modification	Date	revised by
a	First Issue	04.05.1994	Mr. Greiner
b	Pkt. 2.7. Type plate printing changed to Type plate legends Data will be laser printed changed to Data are partially moulded with the lower housing the remaining type-marking will be LASER-printed Pkt. 2.9.6. Dimensions: 495 x 212 x 48 added	14.07.1994	Mr. Greiner
c	CIRCULATION: S. Rodway added Pkt. 3.1.1. Current consumption: 45mA typical changed to Current consumption: 35mA typical	03.08.1994	Mr. Greiner
f	Pkt. 3 Electronic reworked Pkt. 1.3. weighs with original pack. 890g changed to 1193g weighs without original pack. 750g changed to 1040g Pkt. 1.4. Operating life >20 mill. operations changed to Alphanumeric keys min. 20 mill. actuation, Functionalkeys min. 4 mill. actuation Pkt. 7 Approvals: Novel Unix Ware and Novell Net Ware added Pkt. 2.9.4. Material corrugated board... changed to corrugated board: Minimum requirement: Outer layer: 125 Kraftliner, Corrugation: 110, Inner layer: 140 Testliner Pkt. 2.9.6. Dimensions: 495x 212 x 48 changed to 495 x 210 x 47	05.10.1994 21.12.1994	Mr. Köferl Mr. Greiner
g	Pkt. 1.3. Weight with the original packaging approx 1193g changed to 1190g Pkt. 1.6. Keyboard designation G80-6000LAD changed G80-6000LADE Pkt. 2.4.2.and lower grid added Pkt. 2.4.3. PET, 100µm thick changed to textured PET, 125µm thick Pkt. 2.7. Type plate legends changed to Name plate legends Pkt. 3. Electronic reworked Pkt. 4.1.1. Operation min. 0 to 40°C, desired 0 to 50°C changed to desired 0 to 50°C Pkt. 4.2.1. 10 to 85 degree changed to 10 to 85% Pkt. 4.2.2. 10 to 95 degree changed to 10 to 95% Pkt. 4.2.3. 10 to 95 degree changed to 10 to 95% Pkt. 4.3.1.85 degree changed to 85% Pkt. 4.4.1. 10 to 22,5 Hz, travel.... changed to 10 to 22,5 Hz, displacement..... Pkt. 4.4.2. 10 to 16 Hz: travel.... changed to 10 to 16 Hz, displacement Pkt. 4.5.1. (half sine wave) added		

Rev.	Modification	Date	revised by
	Pkt. 4.5.2. (halfsine wave) added		
	Pkt. 4.6.1. Operation: withstands having... changed to bench test to bottom side...		
	Pkt. 4.7. Air pressure changed to Alitude		
	Pkt. 5. Electromangnetic Compatibilit reworked		
	Pkt. 6. Reliability reworked		
	Pkt. 7. Approvals UL changed to UL 1950		
	Pkt. 8. EC Conformity for „CE“-mark added		
00	Pkt. 1.1. Description 104/104 keys added		
	Pkt. 1.6. Keyboard desgnation G80-6000 changed to G83-6000		
	Pkt. 2.2.3. Keycaps number, sizes 104/105 key added		
	Pkt. 2.4.3. Spacer 125 µm changed to 100 µm		
	Pkt. 3.3.2. Typical Power on Diagram added		
	Pkt. 3.5.1. Key numbering 104/104 keys added		
	Pkt. 3.5.2. No. 52/63/65 in Codetable obsoleted		
	Pkt. 3.5.2.1. Appendix 1 for Set 1 added		
	Pkt. 4.7.1 ... equivalent to 565 changed to 665 mbars		
	Pkt. 4.7.2. ... equivalent to 226 changed to 280 mbars		
	Pkt. 6.2.1. Nominal workload changed to Electronics....		
	Pkt. 6.2.2. Maximumum average workload changed to keyboard...		
	Pkt. 6.2.3. obsoleted		
01	Pkt. 2.4.3. complete revised	13.07.1998	E. Goß (Änd.-Nr. 128280)

CONTENTS

1.0 GENERAL

- 1.1. DESCRIPTION**
- 1.2. KEYBOARD COMPONENTS**
- 1.3. WEIGHT**
- 1.4. OPERATING LIFE**
- 1.5. FORCE/TRAVEL DIAGRAM**
- 1.6. KEYBOARD DESIGNATION**
- 1.7. HOUSING/LEGEND VERSIONS**
- 1.8. TECHNICAL DESIGN**
- 1.9. LANGUAGE/COUNTRY VERSIONS**
- 1.10. GENERAL REQUIREMENTS AS PER DIN/ISO**
- 1.11. ERGONOMICS**
- 1.12. UL RECOGNITION**
 - 1.12.1. Plastic parts
 - 1.12.2. PCB
 - 1.12.3. Cables
 - 1.12.4. Membranes
 - 1.12.5. Rubber sheet
- 1.13. ADDITIONAL DOCUMENTS**

2.0 MECHANICAL COMPONENTS

- 2.1. HOUSING**
 - 2.1.1. Colour
 - 2.1.2. Dimensions
 - 2.1.3. Materials
 - 2.1.4. Surface
 - 2.1.5. Adjustable feet
 - 2.1.6. Antislip pads
 - 2.1.7. Inclination
 - 2.1.8. Cleaning
- 2.2. KEYCAPS**
 - 2.2.1. Shape
 - 2.2.2. Colour
 - 2.2.3. Number, sizes
 - 2.2.4. Material
 - 2.2.5. Surface
 - 2.2.6. Legends
 - 2.2.6.1 Type of top legend
 - 2.2.6.2. Colour of top legend
 - 2.2.6.3. Type of front legend
 - 2.2.6.4. Colour of front legend
 - 2.2.6.5. Type style
 - 2.2.7. Layout, position
 - 2.2.7.1. Height of C row
 - 2.2.7.2. Alphanumeric field
 - 2.2.7.3. Deviation from baseline

- 2.2.7.4. Gap between adjacent keycaps
- 2.2.8. Pull-out force
- 2.3. RUBBER SHEET**
 - 2.3.1. Material
 - 2.3.2. Tactile feedback
- 2.4. MEMBRANE**
 - 2.4.1. Material
 - 2.4.2. Printing
 - 2.4.3. Spacer
- 2.5. PCB**
 - 2.5.1. Design
 - 2.5.2. Colour of solder mask
 - 2.5.3. Dimensions
 - 2.5.4. Material
- 2.6. CABLES**
 - 2.6.1. Design
 - 2.6.2. Colour
 - 2.6.3. Length
 - 2.6.4. Plug
- 2.7. NAME PLATE LEGENDS**
- 2.8. LED LEGENDS**
- 2.9. PACKAGING**
 - 2.9.1. Design
 - 2.9.2. Colour
 - 2.9.3. Printing
 - 2.9.4. Materials
 - 2.9.5. Dimensions
 - 2.9.6. Labels

3.0. ELECTRONICS

- 3.1. ELECTRICAL CHARACTERISTICS**
 - 3.1.1. Power supply
 - 3.1.2. Connector Assignment
 - 3.1.3. PCB Connector Assignment
- 3.2. INTERFACE**
 - 3.2.1. Data Output Signal
 - 3.2.2. Data communications
 - 3.2.3. Clock and Data Signals
 - 3.2.4. Timing diagram
 - 3.2.5. Keyboard sends Data
 - 3.2.6. Keyboard receives data
 - 3.2.7. Keyboard Buffer
- 3.3. POWER-ON ROUTINE**
 - 3.3.1. Power-On Reset
 - 3.3.2. Typical Power On Diagramm
 - 3.3.3. Basic Assurance Test

3.4. COMMANDS

3.4.1. Commands from the System

- 3.4.1.1. Default Disable (Hex F5)
- 3.4.1.2. Echo (Hex EE)
- 3.4.1.3. Enable (Hex F4)
- 3.4.1.4. Invalid Command (Hex EF and F1)
- 3.4.1.5. Read ID (Hex F2)
- 3.4.1.6. Resend (Hex FE)
- 3.4.1.7. Reset (Hex FF)
- 3.4.1.8. Select Alternate Scan Codes (Hex F0)
- 3.4.1.9. Set All Keys (Hex F7, F8, F9, FA)
- 3.4.1.10. Set Default (Hex F6)
- 3.4.1.11. Set Key Type (Hex FB, FC, FD)
- 3.4.1.12. Set/Reset Status Indicators (Hex ED)
- 3.4.1.13. Set Typematic Rate/Delay (Hex F3)

3.4.2. Commands to the System

- 3.4.2.1. Acknowledge (Hex FA)
- 3.4.2.2. BAT Completion Code (Hex AA)
- 3.4.2.3. BAT Failure Code (Hex FC)
- 3.4.2.4. Echo (Hex EE)
- 3.4.2.5. Keyboard ID (Hex 83AB)
- 3.4.2.6. Key Detection Error (Hex or FF)
- 3.4.2.7. Overrun (Hex 00 or FF)
- 3.4.2.8. Resend (Hex FE)

3.5. KEYCODES

3.5.1. Key numbering

3.5.2. Codetable

- 3.5.2.1. Appendix 1 for Set 1
- 3.5.2.2. Appendix 1 for Set 2

3.6. CABLE DRAWINGS

4.0. ENVIRONMENTAL CONDITIONS

4.1. TEMPERATURE

- 4.1.1. Operation
- 4.1.2. Storage
- 4.1.3. Transport

4.2. HUMIDITY

- 4.2.1. Operation
- 4.2.2. Storage
- 4.2.3. Transport

4.3. CLIMATE

- 4.3.1. Operation

4.4. VIBRATION

- 4.4.1. Operation
- 4.4.2. Storage

4.5. SHOCK

- 4.5.1. Operation
- 4.5.1. Storage and transport

4.6. Drop resistance

- 4.6.1. Operation
- 4.6.2. Storage and transport

4.7. Altitude

- 4.7.1. Operation
- 4.7.2. Storage and transport

5.0. ELECTROMAGNETIC COMPATIBILITY

5.1. RFI/EMI

5.2. ESD susceptibility

5.3. Immunity to radiated fields

5.4. Burst requirements

6.0 RELIABILITY

6.1. MCBF

6.2. MTBF

- 6.2.1. Electronics
- 6.2.2. Keyboard

7. APPROVALS

8. EC CONFORMITY FOR „CE“-Mark

8.1. Safty

8.2. Electro-Magnetic Compatibility

- 8.2.1. RFI
- 8.2.2. Susceptibility

1.0. GENERAL

This specification describes the requirements for the G83-6000.

1.1. PRODUCT DESCRIPTION

This is a keyboard with 101/102 or 104/105 keys in a housing with Cherry adjustable feet. No options are planned.

G83 -----> Rubber sheet technology

1.2. KEYBOARD COMPONENTS

The keyboard consists of the following principal parts:

- a) Upper housing with light conveyor and keycaps
- b) Lower housing, adjustable feet and antislip pads
- c) Membrane assembly
- d) Rubber sheet
- e) Printed wiring board with electronic components

The upper housing is snapped onto the lower housing. The printed wiring board, the rubber sheet and the membrane are placed in the lower housing. The membrane contacts the PCB by being pressed against it.

1.3. WEIGHT

The keyboard weighs with the original packaging:	approx. 1190 g
without the original packaging:	approx. 1040 g

1.4. OPERATING LIFE

Alpha-Keypad: min. 20 mill actuation
Functional keys min. 4 mill. actuation

1.5. FORCE/TRAVEL DIAGRAM

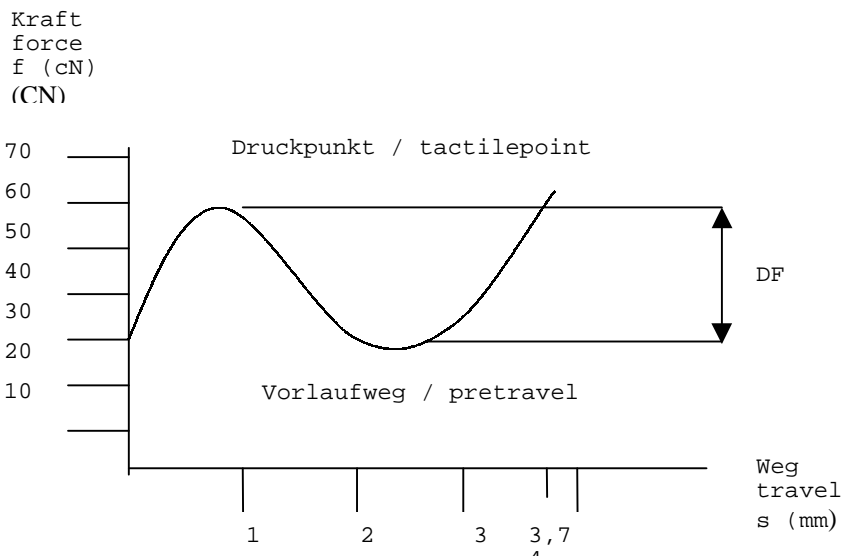

Nominal values:

Tactile point: 0,9mm / 61 cN
Pretravel: 2,4 mm
Total travel: 3,7 mm
Force differential: 26 cN

1.6. KEYBOARD DESIGNATION

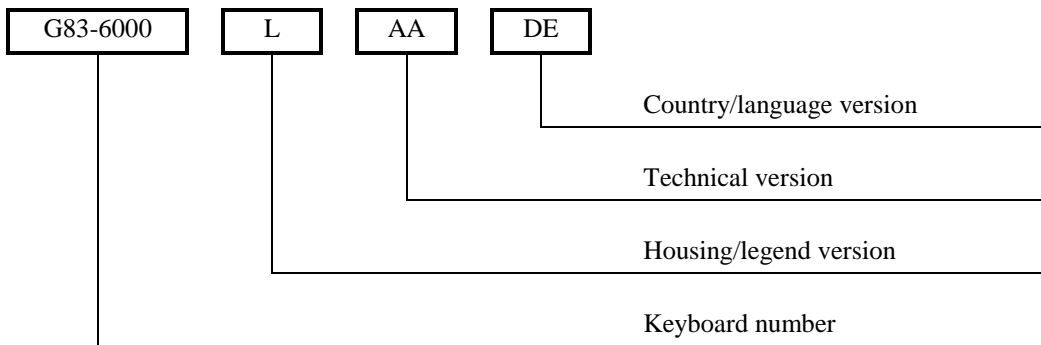

1.7. HOUSING/LEGEND VERSION

L = with housing/laser-printed keycaps
No other letters are specified

1.8. TECHNICAL DESIGN

For detailed listing see DOKT-6000-03 "Technical design"

1.9. COUNTRY/LANGUAGE VERSION

For detailed listing see DOKT-6000-04 "Letter designation for country/language versions"

1.10. GENERAL REQUIREMENTS FOR KEYBOARDS IN COMPLIANCE WITH ISO 9995 AND DIN 2137

1.11. ERGONOMICS AS PER ISO 9241 PART 4, ZH 1/618

1.12. UL-RECOGNIZED MATERIALS/FIRE PROTECTION CLASSES

- 1.12.1. Plastic parts: UL 94 HB
- 1.12.2. Circuit boards: UL 94 V-O
- 1.12.3. Cables: UL-recognized
- 1.12.4. Membranes: UL 4 VTM-2
- 1.12.5. Rubber sheet: UL 94 HB

1.13. Additional documents

Drawings of individual parts	DOKZ-6000-01	Design prints
Symbol films	DOKT-6000-02	Construction overview
FAW's	DOKT-6000-03	Technical design
VAW's	DOKT-6000-04	Letter designations for country/language versions

2.0. MECHANICAL COMPONENTS

2.1. HOUSING

2.1.1. Colour	pearl white
2.1.2. Dimensions	458 x 170 mm
2.1.3. Material	S/B Styrene / butadiene
2.1.4. Surface	as per VDI 3400 No. 36; Ra 6,3 µm
2.1.5. Adjustable feet:	2, with antislip pads
2.1.6. Anti-slip pads	2 pcs.
2.1.7. Inclination	6° and 10°

2.2. KEYCAPS

2.2.1. Shape:	cylindrical ("cyln"), type unilevel
2.2.2. Colour/colour code	white-grey/beige-grey / 6A/6B

2.2.3. Number, sizes:

Version with 101 keys:

83x	1x1		6A/6B
3x	1x1 with dimple (F/J/5)	6A	
6x	1x1,5		6A/6B
1x	1x1,75 stepped	6B	
2x	1x2		6A/6B
2x	1x2,25		6B
2x	1x2 vertical		6B
1x	1x2,75		6B
1x	1x7		6A

Version with 102 keys:

85x	1x1		6A/6B
3x	1x1 with dimple (F/J/5)	6A	
1x	1x1,25		6B
5x	1x1,5		6B
1x	1x1,75 stepped	6B	
2x	1x2		6B/6A
2x	1x2 vertical		6B
1x	1x2,75		6B
1x	1,5x2x1,25		6B
1x	1x7		6A

Version with 104 keys

83x	1x1		6A/6B
3x	1x1 with dimple (F/J/5)	6A	
7x	1x1,25		6B
2x	1x1,5		6A/6B
1x	1x1,75 stepped	6B	
2x	1x2		6A/6B
2x	1x2 vertical		6B
2x	1x2,25		6B
1x	1x2,75		6B
1x	1x6,25		6A

Version with 105 keys

85x	1x1	6A/6B
3x	1x1 with dimple (F/J/5)	6A
8x	1x1,25	6B
1x	1x1,5	6B
1x	1x1,75 stepped	6B
2x	1x2	6A/6B
2x	1x2 vertical	6B
1x	1x2,75	6B
1x	1,5x2x1,25	6B
1x	1x6,25	6A

- 2.2.4. Material PBT
- 2.2.5. Surface eroded, Rt 18 µm
- 2.2.6. Legends:
 - 2.2.6.1. Type of top legend: laser-printed
 - 2.2.6.2. Colour/colour code of top legend: black
 - 2.2.6.3. Type of front legends: laser-
printed/tampo-
printing optionally
possible
 - 2.2.6.4. Colour of front legends: black
 - 2.2.6.5. Typestyle: Formula One
- 2.2.7. Layout, position
 - 2.2.7.1. Height of C row 29,5 mm
 - 2.2.7.2. Typewriter area: as per DIN 2137
 - 2.2.7.3. Deviation from baseline of a row: < 0,5 mm
 - 2.2.7.4. Gap between two adjacent keycaps: Variance of
+/- 0,5mm
- 2.2.8. Pull-off force: 6N < F < 30 N
- 2.3. RUBBER SHEET
 - 2.3.1. Material: two-component silicone rubber (LSR)
 - 2.3.2. Tactile feedback: tactile point
- 2.4. MEMBRANE
 - 2.4.1. Membrane material: PET, 100 µm thick
 - 2.4.2. Printing: Tracks with conductive silver ink approx 7 µmthick, plus carbon printing on outside of upper membrane and lower grid
 - 2.4.3. Spacer: PET, 100 µm thick textured / embossed up to 125 µm thickness

2.5. PCB

- 2.5.1. Type: one side with Cu 35/00 μm chem. nickel 4 - 5 μm
chem. gold 0,1 - 0,3 μm
- 2.5.2. Colour: solder resist, green, on solder side
- 2.5.3. Dimensions: 59 x 27,5 x 1,5 mm
- 2.5.4. Material: FR2 (UL 94 V-0) or
FR1 (UL 94 V-0) or
FR3 (UL 94V-0) or
FR4 (UL 94V-0)

2.6. CABLES:

- 2.6.1. Type: round with and without coil
- 2.6.2. Colour: gravel-grey (RAL 7032)
- 2.6.3. Length: 1750 mm from housing in version without coil
- 2.6.4. Connector: 5-pin shielded DIN connector or mini-DIN
connector other end plug connected

2.7. NAME PLATE LEGENDS

Data are partially moulded in bottom housing, the additional datas will be Laser-printed

2.8. LED LEGENDS

Laser-printed on upper housing

2.9. PACKAGING

- 2.9.1. Type: single packaging; corrugated collapsible box
board
- 2.9.2. Colour: brown
- 2.9.3. Printing: none
- 2.9.4. Material: corrugated board
Minimum requirement:
Outer layer: 125 Kraftliner
Corrugation: 110
Inner layer: 140 Testliner
- 2.9.5. Labels: printed paper
- 2.9.6. Dimensions: 495 x 210 x 47

3. ELECTRONICS

3.1 ELECTRICAL CHARACTERISTICS

3.1.1 Power Supply

	Min.	Typ.	Max.
Voltage	4,75 V	5 V	5,25 V
safety extra low voltage (SELV)			
Current 3 LED's ON	tbd	35 mA	tbd
Current 3 LED's OFF	tbd	5 mA	tbd

3.1.2 Connector Assignment

DIN Connector Signals

MINI DIN Connector

1	Clock	5
2	Data	1
3	nc	2/6
4	Ground	3
5	+5 Volt	4
Shell	Shield	Shell

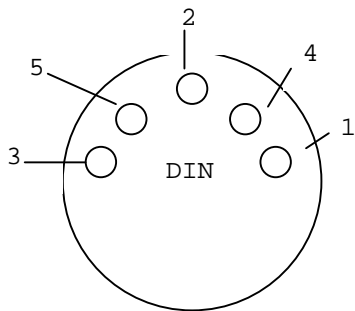

Connectorpins
Front-View

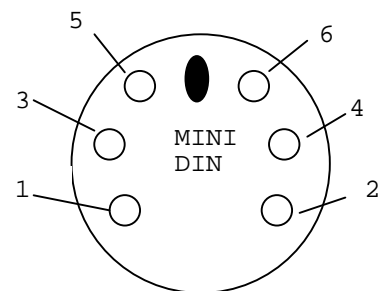

3.2 INTERFACE

3.2.1 Data Output Signal

Bidirectional synchronous format. IBM-AT-compatible. Open drain.

CLOCK/DATA	MIN.	MAX.
V _{out} low	0	0,7 V
V _{out} high	2,4 V	5,25 V

3.2.2 Data communications

- 1 Startbit (always 0)
- 8 Databits
- 1 Paritybit odd
- 1 Stopbit (always 1)

3.2.3 Clock and Data Signals

The keyboard and the system communicate over the clock and data lines. The source of each of these lines is an open-drain device on the keyboard that allows either the keyboard or the system to force a line to low level. When no communication is occurring, the clock and datalines are on high level kept by pull-up resistors.

When the system sends data to the keyboard, it forces the data line to low level until the keyboard starts to clock the data stream.

The keyboard clock line provides the clocking signals used to clock serial data to and from the keyboard. If the host system forces the clock line to an low level, keyboard transmission is inhibited.

When the keyboard sends data to or receives data from the system it generates the clock signal to time the data. The system can prevent the keyboard from sending data by forcing the clock line to low level, the data line may be high or low during this time.

During the BAT, the keyboard allows the clock and data line to go to high level.

3.2.4 Timing diagram

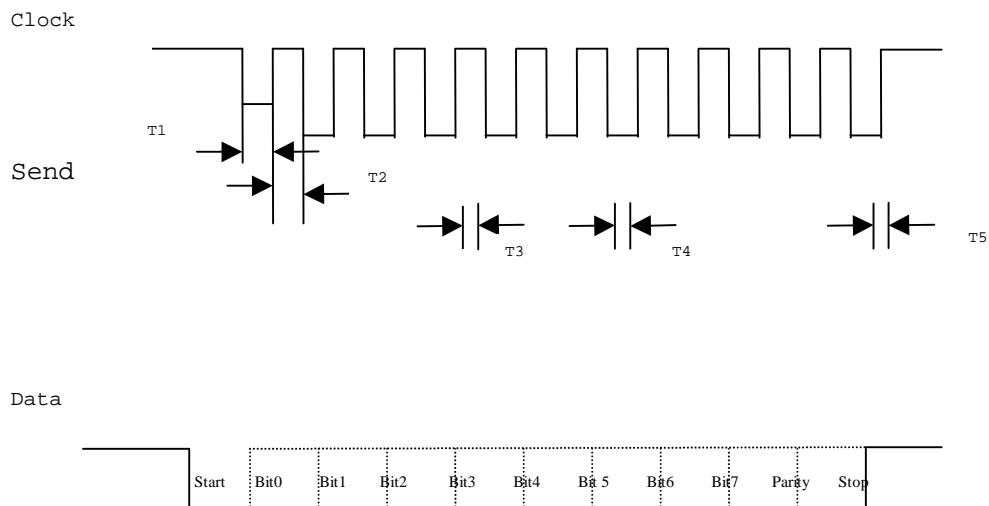

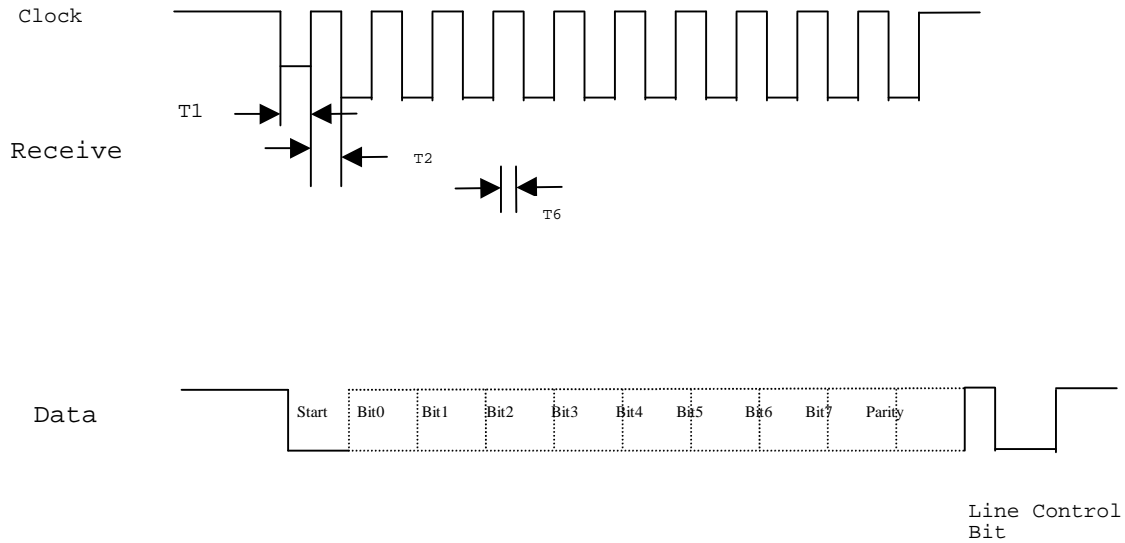

T1	30<50µs
T2	30<50µs
T3	5<25µs
T4	5<T2-5µs
T5	0<50µs
T6	5<25µs

3.2.5 Keyboard sends Data

When the keyboard is ready to send data, it first checks for a keyboard-inhibit or system request-to-send status on the clock and data lines. If the clock line is low, data is stored in the keyboard buffer. If the clock line is high and the data line is low (request-to send), data is stored in the keyboard buffer, and the keyboard receives system data.

If the clock and data lines are both high the keyboard sends the (0) start bit, 8 data bits, the parity bit and the stop bit. Data will be valid before the trailing edge and beyond the leading edge of the clock pulse. During transmission, the keyboard checks the clock line for low level at least every 60 µseconds. If the system lowers the clock line after the keyboard starts sending data, a condition known as line contention occurs, and the keyboard stops sending data. If line contention occurs before the leading edge of the 10th clock signal (parity bit), the keyboard buffer returns the clock and data lines to high level. If contention does not occur by the 10th clock signal, the keyboard completes the transmission. Following line contention, the system may or may not request the keyboard to resend the data.

Following a transmission, the system can inhibit the keyboard until the system processes the input or until it requests that a response be sent.

3.2.6 Keyboard receives data

When the system is ready to send data to the keyboard, it first checks to see if the keyboard is sending data. If the keyboard is sending, but has not reached the 10th clock signal, the system can override the keyboard output by forcing the keyboard clock line to low level. If the keyboard transmission is beyond the 10th clock signal, the system must receive the transmission.

If the keyboard is not sending or if the system elects to override the keyboard's output, the system forces the keyboard clock line to low level for more than 60 microseconds while preparing to send data. When the system is ready to send the start bit (the data line will be low), it allows the clock line to go to high level.

The keyboard checks the state of the clock line at intervals of no more than 10 milliseconds. If a system request-to-send (RTS) is detected, the keyboard counts 11 bits. After the 10th bit, the keyboard checks for high level on the data line, and if the line is high forces it low, and counts one more bit. This action signals the system that the keyboard has received its data. Upon receipt of this signal, the system returns to a ready state, in which it can accept keyboard output or goes to the inhibited state until it is ready.

If the keyboard data line is found at low level following the 10th bit, a framing error has occurred, and the keyboard continues to count until the data line becomes high. The keyboard then makes the data line low and sends a Resend.

Each system command or data transmission to the keyboard requires a response from the keyboard before the system can send its next output. The keyboard will respond within 20 milliseconds unless the system prevents keyboard output. If the keyboard response is invalid or has a parity error, the system sends the command or data again. However, the two byte commands require special handling. If hex F3 (Set Typematic Rate/Delay), hex F0 (Select Alternate Scan Codes), or hex ED (Set/Reset Mode Indicators) have been sent and acknowledged, and the value byte has been sent but the response is invalid or has a parity error, the system will resend both the command and the value byte.

3.2.7 Keyboard Buffer

A 16-byte first-in-first-out (FIFO) buffer in the keyboard stores the scan codes until the system is ready to receive them.

A buffer-overflow condition occurs when more than 16 bytes are placed in the keyboard buffer. An overflow code replaces the 17th byte. If more keys are pressed before the system allows keyboard output, the additional data is lost.

When the keyboard is allowed to send data, the bytes in the buffer will be sent as in normal operation, and new data entered is detected and sent. Response codes do not occupy a buffer position.

If keystrokes generate a multiple-byte sequence, the entire sequence must fit into

the available buffer space or the keystroke is discarded and a buffer-overflow condition occurs.

3.3. POWER-ON-ROUTINE

3.3.1 Power-On Reset

The keyboard logic generates a 'power-on-reset' signal (POR) when power is first applied to the keyboard. POR occurs a minimum of 150 milliseconds and a maximum of 2.0 seconds from the time power is first applied to the keyboard.

3.3.2. Typical Power on Diagram

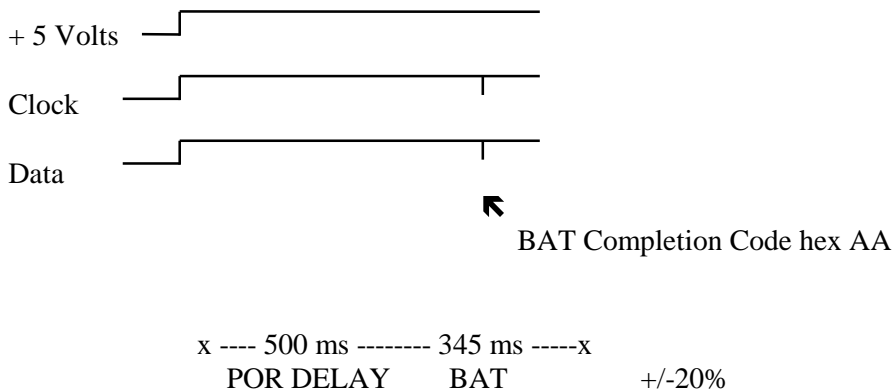

3.3.3 Basic Assurance Test

The basic assurance test (BAT) consists of a keyboard processor test, a checksum of the read-only memory (ROM), and a random-access memory (RAM) test. During the BAT, activity on the "clock" and "data" lines is ignored. The LEDs are turned on at the beginning and off at the end of the BAT. The BAT takes a minimum of 300 milliseconds and a maximum of 500 milliseconds. This is in addition to the time required by the POR.

Upon satisfactory completion of the BAT, a completion code (hex AA) is sent to the system, and keyboard scanning begins. If a BAT failure occurs, the keyboard sends an error code to the system. The keyboard is then disabled pending command input. Completion codes are sent between 450 milliseconds and 2.5 seconds after POR, and between 300 and 500 milliseconds after a Reset command is acknowledged.

3.4 COMMANDS

3.4.1 Commands from the System

The following table shows the command that the system may send and their hexadecimal values.

Command	Hex Value
Set/Reset Status Indicators	ED
Echo	EE
Invalid Command	EF
Select Alternate Scan Codes	F0
Invalid Command	F1
Read ID	F2
Set Typematic Rate/Delay	F3
Enable	F4
Default Disable	F5
Set Default	F6
Set All Keys - Typematic	F7
- Make/Break	F8
- Make	F9
- Typematic/Make/Break	FA
Set Key Type - Typematic	FB
- Make/Break	FC
- Make	FD
Resend	FE
Reset	FF

The Commands may be sent to the keyboard at any time. The keyboard will respond within 20 milliseconds, except when performing the basic assurance test (BAT), or executing a Reset command.

3.4.1.1 Default Disable (Hex F5)

The Default Disable command resets all conditions to the power-on default state. The keyboard responds with ACK, clears its output buffer, sets the default key types (scan code set 3 operation only) and typematic rate/delay, and clears the last typematic key. The keyboard stops scanning and awaits further instructions.

3.4.1.2 Echo (Hex EE)

Echo is a diagnostic aid. When the keyboard receives this command, it issues a hex EE response and, if the keyboard was previously enabled, continues scanning.

3.4.1.3 Enable (Hex F4)

Upon receipt of this command, the keyboards responds with ACK, clears its output buffer, clears the last typematic key, and starts scanning.

3.4.1.4 Invalid Command (Hex EF and F1)

Hex EF and hex F1 are invalid commands and are not supported. If one of these is

sent, the keyboard does not acknowledge the command, but returns a Resend command and continues in its prior scanning state. No other activities occur.

3.4.1.5 Read ID (Hex F2)

This command requests identification information from the keyboard. The keyboard responds with ACK, discontinues scanning and sends the two keyboard ID bytes. The second byte must follow completion of the first by no more than 500 microseconds. After the output of the second ID byte, the keyboard resumes scanning.

3.4.1.6 Resend (Hex FE)

The system sends this command when it detects an error in any transmission from the keyboard. It is sent only after a keyboard transmission and before the system allows the next keyboard output. When a Resend is received, the keyboard sends the previous output again (unless the previous output was Resend, in which case the keyboard sends the last byte before the Resend command).

3.4.1.7 Reset (Hex FF)

The system issues a Reset command to start a program reset and a keyboard internal self test. The keyboard acknowledges the command with an ACK and ensures the system accepts ACK before executing the command. The system signals acceptance of ACK by raising the clock and data lines for a minimum of 500 microseconds. The keyboard is disabled from the time it receives the Reset command until ACK is accepted or until another command is sent that overrides the previous command.

Following acceptance of ACK, the keyboard is re-initialized and performs the BAT. After returning the completion code, the keyboard defaults to scan code set 2.

3.4.1.8 Select Alternate Scan Codes (Hex F0)

This command instructs the keyboard to select one of three sets of scan codes. The keyboard acknowledges receipt of this command with ACK, clears both the output buffer and the typematic key (if one is active). The system then sends the option byte and the keyboard responds with another ACK. An option byte value of hex 01 selects scan code set 1, hex 02 selects set 2 and hex 03 selects set 3.

An option byte value of hex 00 causes the keyboard to acknowledge with ACK and send a byte telling the system which scan code set is currently in use.

After establishing the new scan code set, the keyboard returns to the scanning state it was in before receiving the Select Alternate Scan Codes command.

3.4.1.9 Set All Keys (Hex F7, F8, F9, FA)

These commands instruct the keyboard to set all keys to the type listed below:

Hex Value	Command
F7	Set All Keys - Typematic
F8	Set All Keys - Make/Break
F9	Set All Keys - Make
FA	Set All Keys - Typematic/Make/Break

The keyboard responds with ACK, clears its output buffer, sets all keys to the type indicated by the command and continues scanning (if it was previously enabled). Although these commands can be sent using any scan code set, they affect only scan code set 3 operation.

3.4.1.10 Set Default (Hex F6)

The Set Default command resets all conditions to the power-on default state. The keyboard responds with ACK, clears its output buffer, sets the default key types (scan code set 3 operation only) and typematic rate/delay, clears the last typematic key and continues scanning.

3.4.1.11 Set Key Type (Hex FB, FC, FD)

These commands instruct the keyboard to set individual keys to the type listed below:

Hex Value	Command
FB	Set Key Type - Typematic
FC	Set Key Type - Make/Break
FD	Set Key Type - Make

The keyboard responds with ACK, clears its output buffer and prepares to receive key identification. Key identification is accomplished by the system identifying each key by its scan code value as defined in scan code set 3. Only scan code set 3 values are valid for key identification. The type of each identified key is set to the value indicated by the command.

These commands can be sent using any scan code set, but affect only scan code set 3 operation.

3.4.1.12 Set/Reset Status Indicators (Hex ED)

Three status indicators on the keyboard - Num Lock, Caps Lock and Scroll Lock - are accessible by the system. The keyboard activates or deactivates these indicators when it receives a valid command-code sequence from the system. The command sequence begins with the command byte (hex ED). The keyboard responds to the command byte with ACK, discontinues scanning and waits for the option byte from the system. The bit assignments for this option byte are as follows:

Bit	Indicator
0	Scroll Lock Indicator
1	Num Lock Indicator
2	Caps Lock Indicator
3 - 7	Reserved (bust be 0s)

If a bit for an indicator is set to 1, the indicator is turned on. If a bit is set to 0, the indicator is turned off.

The keyboard responds to the option byte with ACK, sets the indicators and, if the keyboard was previously enabled, continues scanning. The state of the indicators will reflect the bits in the option byte and can be activated or deactivated in any combination. If another command is received in place of the option byte, execution of the Set/Reset Mode Indicators command is stopped, with no change to the indicator states and the new command is processed.

Immediately after power-on, the lights default to the Off state. If the Set Default and Default Disable commands are received, the lamps remain in the state they were in before the command was received.

3.4.1.13 Set Typematic Rate/Delay (Hex F3)

The system issues the Set Typematic Rate/Delay command to change the typematic rate and delay. The keyboard responds to the command with ACK, stops scanning and waits for the system to issue the rate/delay value byte. The keyboard responds to the Rate/delay value byte with another ACK, sets the rate and delay to the values indicated and continues scanning (if it was previously enabled). Bits 6 and 5 indicate the delay and bits 4, 3, 2, 1 and 0 (the least-significant bit) the rate. Bit 7, the most-significant bit, is always 0. The delay is equal to 1 plus the binary value of bits 6 and 5, multiplied by 250 milliseconds $\pm 20\%$.

The typematic rate (make codes per second) is 1 for each period and are listed in the following table.

Bit	Typematic Rate ± 20 %		Bit	Typematic Rate ± 20 %
00000	30.0		10000	7.5
00001	26.7		10001	6.7
00010	24.0		10010	6.0
00011	21.8		10011	5.5
00100	20.0		10100	5.0
00101	18.5		10101	4.6
00110	17.1		10110	4.3
00111	16.0		10111	4.0
01000	15.0		11000	3.7
01001	13.3		11001	3.3
01010	12.0		11010	3.0
01011	10.9		11011	2.7
01100	10.0		11100	2.5
01101	9.2		11101	2.3
01110	8.0		11110	2.1
01111	8.0		11111	2.0

The default values for the system keyboard are as follows:

Typematic rate = 10.9 characters per second ± 20 %

Delay = 500 milliseconds ± 20 %

The execution of this command stops without change to the existing rate if another command is received instead of the rate/delay value byte.

3.4.2 Commands to the System

The following table shows the commands that the keyboard may send to the system and their hexadecimal values.

Command	Hex Value
Key Detection Error/Overrun	00 (Code Sets 2 and 3)
Keyboard ID	83AB
BAT Completion Code	AA
BAT Failure Code	FC
Echo	EE
Acknowledge (ACK)	FA
Resent	FE
Key Detection Error/Overrun	FF (Code Set 1)

The commands the keyboard sends to the system are described below, in alphabetic order.

3.4.2.1 Acknowledge (Hex FA)

The keyboard issues Acknowledge (ACK) to any valid input other than an Echo or Resend command. If the keyboard is interrupted while sending ACK, it discards ACK and accepts and responds to the new command.

3.4.2.2 BAT Completion Code (Hex AA)

Following satisfactory completion of the BAT, the keyboard sends hex AA. Any other code indicates a failure of the keyboard.

3.4.2.3 BAT Failure Code (Hex FC)

If a BAT failure occurs, the keyboard sends this code, discontinues scanning and waits for a system response or reset.

3.4.2.4 Echo (Hex EE)

The keyboard sends this code in response to an Echo command.

3.4.2.5 Keyboard ID (Hex 83AB)

The Keyboard ID consists of 2 bytes, hex 83AB. The keyboard responds to the Read ID with ACK, discontinues scanning, and sends the 2 ID bytes. The low byte is sent first followed by the high byte. Following output of Keyboard ID, the keyboard begins scanning.

3.4.2.6 Key Detection Error (Hex 00 or FF)

The keyboard sends a key detection error character if conditions in the keyboard make it impossible to identify a switch closure. If the keyboard is using scan code set 1, the code is hex FF. For sets 2 and 3, the code is hex 00.

3.4.2.7 Overrun (Hex 00 or FF)

An overrun character is placed in the keyboard buffer and replaces the last code when the buffer capacity has been exceeded. The code is sent to the system when it reaches the top of the buffer queue. If the keyboard is using scan code set 1, the code is hex FF. For sets 2 and 3, the code is hex 00.

3.4.2.8 Resend (Hex FE)

The keyboard issues a Resend command following receipt of an invalid input or any input with incorrect parity. If the system sends nothing to the keyboard, no response is required.

3.5 KEYCODES

101 keys (US)

110	112 113 114 115	116 117 118 119	120 121 122 123	124 125 126
-----	-----------------	-----------------	-----------------	-------------

1	2	3	4	5	6	7	8	9	10	11	12	13	15	75	80	85	90	95	100	105
16	17	18	19	20	21	22	23	24	25	26	27	28	29	76	81	86	91	96	101	106
30	31	32	33	34	35	36	37	38	39	40	41	43				92	97	102		
44	46	47	48	49	50	51	52	53	54	55	57		83		93	98	103	108		
58	60	61						62	64	79	84	89	99	104						

102 keys (EUROPE)

110	112 113 114 115	116 117 118 119	120 121 122 123	124 125 126
-----	-----------------	-----------------	-----------------	-------------

1	2	3	4	5	6	7	8	9	10	11	12	13	15	75	80	85	90	95	100	105
16	17	18	19	20	21	22	23	24	25	26	27	28	43	76	81	86	91	96	101	106
30	31	32	33	34	35	36	37	38	39	40	41	42				92	97	102		
44	45	46	47	48	49	50	51	52	53	54	55	57		83		93	98	103	108	
58	60	61						62	64	79	84	89	99	104						

104 keys (US)

110	112 113 114 115	116 117 118 119	120 121 122 123	124 125 126
-----	-----------------	-----------------	-----------------	-------------

1	2	3	4	5	6	7	8	9	10	11	12	13	15	75	80	85	90	95	100	105
16	17	18	19	20	21	22	23	24	25	26	27	28	29	76	81	86	91	96	101	106
30	31	32	33	34	35	36	37	38	39	40	41	43				92	97	102		
44	46	47	48	49	50	51	52	53	54	55	57		83		93	98	103	108		
58	59	60	61						62	63	65	64	79	84	89	99	104			

105 keys (EUROPE)

110	112 113 114 115	116 117 118 119	120 121 122 123	124 125 126
-----	-----------------	-----------------	-----------------	-------------

1	2	3	4	5	6	7	8	9	10	11	12	13	15	75	80	85	90	95	100	105
16	17	18	19	20	21	22	23	24	25	26	27	28	43	76	81	86	91	96	101	106
30	31	32	33	34	35	36	37	38	39	40	41	43				92	97	102		
44	45	46	47	48	49	50	51	52	53	54	55	57		83		93	98	103	108	
58	59	60	61						62	63	65	64	79	84	89	99	104			

3.5.2 Codetable

Key number	Set 1	Set 2	Set 3	
1	29	0E	0E	T
2	02	16	16	T
3	03	1E	1E	T
4	04	26	26	T
5	05	25	25	T
6	06	2E	2E	T
7	07	36	36	T
8	08	3D	3D	T
9	09	3E	3E	T
10	0A	46	46	T
11	0B	45	45	T
12	0C	4E	4E	T
13	0D	55	55	T
15	0E	66	66	T
16	0F	0D	0D	T
17	10	15	15	T
18	11	1D	1D	T
19	12	24	24	T
20	13	2D	2D	T
21	14	2C	2C	T
22	15	35	35	T
23	16	3C	3C	T
24	17	43	43	T
25	18	44	44	T
26	19	4D	4D	T
27	1A	54	54	T
28	1B	5B	5B	T
29	2B	5D	5C	T
30	3A	58	14	MB
31	1E	1C	1C	T
32	1F	1B	1B	T
33	20	23	23	T
34	21	2B	2B	T
35	22	34	34	T
36	23	33	33	T
37	24	3B	3B	T
38	25	42	42	T
39	26	4B	4B	T
40	27	4C	4C	T
41	28	52	52	T
42	2B	5D	53	T
43	1C	5A	5A	T
44	2A	12	12	MB
45	56	61	13	T
Key number	Set 1	Set 2	Set 3	
46	2C	1A	1A	T

47	2D	22	22	T
48	2E	21	21	T
49	2F	2A	2A	T
50	30	32	32	T
51	31	31	31	T
52	32	3A	3A	T
53	33	41	41	T
54	34	49	49	T
55	35	4A	4A	T
57	36	59	59	MB
58	1D	14	11	MB
59	E0 5B	E0 1F	8B	MB
60	38	11	19	MB
61	39	29	29	T
62	E0/38	E0/11	39	M
63	E0 5C	E0 27	8C	MB
64	E0/1D	E0/14	58	M
65	E0 5D	E0 2F	8D	MB
75 see app. 1			67	M
76 see app. 1			64	T
79 see app. 1			61	T
80 see app. 1			6E	M
81 see app. 1			65	M
83 see app. 1			63	T
84 see app. 1			60	T
85 see app. 1			6F	M
86 see app. 1			6D	M
89 see app. 1			6A	T
90	45	77	76	M
91	47	6C	6C	M
92	4B	6B	6B	M
93	4F	69	69	M
95 see app. 1			77	M
96	48	75	75	M
97	4C	73	73	M
98	50	72	72	M
99	52	70	70	M
100	37	7C	7E	M
101	49	7D	7D	M
102	4D	74	74	M
103	51	7A	7A	M
104	53	71	71	M
105	4A	7B	84	M
106	4E	79	7C	T
108	E0/1C	E0/5A	79	M
110	01	76	08	M
112	3B	05	07	M
Key number	Set 1	Set 2	Set 3	
113	3C	06	0F	M
114	3D	04	17	M
115	3E	0C	1F	M

116	3F	03	27	M
117	40	0B	2F	M
118	41	83	37	M
119	42	0A	3F	M
120	43	01	47	M
121	44	09	4F	M
122	57	78	56	M
123	58	07	5E	M

Key number	Set 1	Set 2	Set 3	
124 see app. 1			57	M
125	46	7E	5F	M
126 see app. 1			62	M

Key Type Default: M = Make only
 T = Typematic
 MB = Make-Break

3.5.2.1. Appendix 1 for Set 1

Key-number	Base Case, or Shift + Num Lock Make/Break	Shift Case Make/Break *	Num Lock on Make/Break
75	E0 52 /E0 D2	E0 AA E0 52 /E0 D2 E0 2A	E0 2A E0 52 /E0 D2 E0 AA
76	E0 53 /E0 D3	E0 AA E0 53 /E0 D3 E0 2A	E0 2A E0 53 /E0 D3 E0 AA
79	E0 4B /E0 CB	E0 AA E0 4B /E0 CB E0 2A	E0 2A E0 4B /E0 CB E0 AA
80	E0 47 /E0 C7	E0 AA E0 47 /E0 C7 E0 2A	E0 2A E0 47 /E0 C7 E0 AA
81	E0 4F /E0 CF	E0 AA E0 4F /E0 CF E0 2A	E0 2A E0 4F /E0 C7 E0 AA
83	E0 48 /E0 C8	E0 AA E0 48 /E0 C8 E0 2A	E0 2A E0 48 /E0 C8 E0 AA
84	E0 50 /E0 D0	E0 AA E0 50 /E0 D0 E0 2A	E0 2A E0 50 /E0 D0 E0 AA
85	E0 49 /E0 C9	E0 AA E0 49 /E0 C9 E0 2A	E0 2A E0 49 /E0 C9 E0 AA
86	E0 51 /E0 D1	E0 AA E0 51 /E0 D1 E0 2A	E0 2A E0 51 /E0 D1 E0 AA
89	E0 4D /E0 CD	E0 AA E0 4D /E0 CD E0 2A	E0 2A E0 4D /E0 CD E0 AA

	Scan Code Make / Break	Ctrl Case, Shift Case Make / Break	Alt Case Make / Break
124	E0 2A E0 37 /E0 B7 E0 AA	E0 37 / E0 B7	54 / D4

	Make Code	Ctrl Key pressed
126	E1 1D 45 E1 9D C5	E0 46 E0 C6
This key is not typematic. All associated scan codes occur on the make of the key		

	Scan Code Make/Break	Shift Case Make / Break*
95	E0 35 / E0 B5	E0 AA E0 35 / E0 B5 E0 2A
* If the left Shift key is held down, the F0 AA/2A shift make and break is sent with the other scan codes. If the right Shift key is held down, B6/36 is sent. If both Shift Keys are down, both sets of codes are sent with the other scan codes.		

3.5.2.1 Appendix 1 for Set 2

Key-number	Base Case, or Shift + Num Lock Make/Break	Shift Case Make/Break *	Num Lock on Make/Break
75	E0 70 /E0 F0 70	E0 F0 12 E0 70 /E0 F0 70 E0 12	E0 12 E0 70 /E0 F0 70 E0 F0 12
76	E0 71 /E0 F0 71	E0 F0 12 E0 71 /E0 F0 71 E0 12	E0 12 E0 71 /E0 F0 71 E0 F0 12
79	E0 6B /E0 F0 6B	E0 F0 12 E0 6B /E0 F0 6B E0 12	E0 12 E0 6B /E0 F0 6B E0 F0 12
80	E0 6C /E0 F0 6C	E0 F0 12 E0 6C /E0 F0 6C E0 12	E0 12 E0 6C /E0 F0 6C E0 F0 12
81	E0 69 /E0 F0 69	E0 F0 12 E0 69 /E0 F0 69 E0 12	E0 12 E0 69 /E0 F0 69 E0 F0 12
83	E0 75 /E0 F0 75	E0 F0 12 E0 75 /E0 F0 75 E0 12	E0 12 E0 75 /E0 F0 75 E0 F0 12
84	E0 72 /E0 F0 72	E0 F0 12 E0 72 /E0 F0 72 E0 12	E0 12 E0 72 /E0 F0 72 E0 F0 12

Key-number	Base Case, or Shift + Num Lock Make/Break	Shift Case Make/Break *	Num Lock on Make/Break
85	E0 7D /E0 F0 7D	E0 F0 12 E0 7D /E0 F0 7D E0 12	E0 12 E0 7D /E0 F0 7D E0 F0 12
86	E0 7A /E0 F0 7A	E0 F0 12 E0 7A /E0 F0 7A E0 12	E0 12 E0 7A /E0 F0 7A E0 F0 12
89	E0 74 /E0 F0 74	E0 F0 12 E0 74 /E0 F0 74 E0 12	E0 12 E0 74 /E0 F0 74 E0 F0 12

	Scan Code Make / Break	Ctrl Case, Shift Case Make / Break	Alt Case Make / Break
124	E0 12 E0 7C /E0 F0 7C E0 F0 12	E0 7C / E0 F0 7C	84 / F0 84

	Make Code	Ctrl Key pressed
126	E1 14 77 E1 F0 14 F0 77	E0 7E E0 F0 7E
This key is not typematic. All associated scan codes occur on the make of the key		

	Scan Code Make/Break	Shift Case Make / Break*
95	E0 4A / E0 F0 4A	E0 F0 12 E0 4A / E0 F0 4A E0 12
* If the left Shift key is held down, the F0 12/12 shift make and break is sent with the other scan codes. If the right Shift key is held down, F0 59/59 is sent. If both Shift Keys are down, both sets of codes are sent with the other scan codes.		

3.6 CABLE DRAWING

3.6.1 Uncoiled cable with DIN-connector

Drawing 617-1284

3.6.2 Uncoiled cable with min-DIN-connector

Drawing 617-1300

3.6.3 Coiled cable with DIN-connector

Drawing 617-1301

3.6.5 Coiled cable with DIN-connector

Drawing 617-1302

3.7 Circuit diagram

Drawing 620-0818**4.0. ENVIRONMENTAL CONDITIONS**

4.1. Temperature

- 4.1.1. Operation: 0 to 50° C
- 4.1.2. Storage: -20 to + 60° C
- 4.1.3. Transportation: -20 to + 65° C

4.2. Humidity

- 4.2.1. Operation: 10 to 85 % r.h. non-condensing
- 4.2.2. Storage: 10 to 95 % r.h. non-condensing
- 4.2.3. Transport: 10 to 95 % r.h. non-condensing

4.3. Climate

- 4.3.1. Operation: DIN IEC 721-3 class 3K3 40° C, 85% r.h.
(corresponding to a dew point at plus 37° C)

4.4. Vibration

- 4.4.1. Operation: 10 to 22,5 Hz: displacement 0,25 mm (peak to peak)
22,5 to 300Hz: acceleration 0,25 g peak
- 4.4.2. Storage and transport (in original packaging):
10 to 16 Hz: displacement 3 mm (peak to peak)
16 to 500 Hz: acceleration 1,5 g

4.5. Shock

- 4.5.1. Operation: acceleration: 10 g for duration of 16 ms (halfsine wave)
- 4.5.2. Storage: acceleration: 25 g for duration of 6 ms (halfsine wave)

4.6. Drop resistance

- 4.6.1. Operation bench test to bottom side: height of 50 mm
(pitch of 30 degrees)
- 4.6.2. Storage and transport (in original packaging):
free fall from height of 70 cm

4.7. Altitude

- 4.7.1. Operation: height of 2,4 km (8000 feet), equivalent to 665 mbars
- 4.7.2. Storage: height of 9,1 km (30.000 feet), equivalent to 280 mbars

5.0. ELECTROMANGNETIC COMPATIBILITY

- 5.1. RFI/EMI
FCC part 15, subpart B, Class B (margin 6dB)
EN 55022 class B (margin 6dB)
- 5.2. ESD susceptibility (IEC 801-2)
- Insulation (housing): 8kV air discharge (Level 3)
 - Key area: 15 kV air discharge (Level 4)
 - Indirect discharge:
 - * discharge to horizontal couplin plane: 4 kV contact discharge (Level 2)
15 kV air discharge (Level 4)
 - * discharge to PC-housing: 4 kV contact discharge (Level 2)
8 kV air discharge (Level 3)
- 5.3. Immunity to radiated fields (IEC 801-3)
10 V/m (level 3)
- 5.4. Burst immunity (IEC 801-4)
capacitiv coupling into keyboard cable: +/- 300V

6. RELIABILITY

- 6.1. MCBF
10⁹ actuations
- 6.2. MTBF
- 6.2.1. Electronics: ≥ 1.000.000 h
 - 6.2.2. Keyboard: ≥ 100.000 h

7.0. APPROVALS

UL 1950
CSA C22.2 No. 950
FCC Part 15, subpart B, class B
VDE/GS
CE certification
Novell Unix Ware
Novell Net Ware

8.0. EC CONFORMITY FOR „CE“-MARK

- 8.1. Safety: EN 60950
according Low Voltage Directive 73/23/EEC

- 8.2. Electro-magnetic Compatibility (EMC)
according EMC Directive 89/33/EEC
 - 8.2.1. RFI: EN 55022: 1987 Class B
 - 8.2.2. Susceptibility according EN 50082-1: 1992
 - 8.2.2.1. ESD: IEC 801-2 (1991) Level 2
(indirect discharge)
 - 8.2.2.2. Radiated fields: IEC 801-3 (1994): Level 2

End of list